

## Patterns

[accordion](#) | [disoriented](#) | [beach](#) | [rosedale](#) | [saity](#) | [tilt](#) | [sonnet](#)  
[bpt](#) | [flashy](#) | [villa](#) | [boo](#) | [latifa](#) | [banshee](#) | [penny](#) | [hoover](#) | [rosedaleII](#)

## Tilt

by Natalie Wilson

### piquant

This is not a project for those who prefer mindless knitting.

But if you enjoy following charts, you will be rewarded for your concentration with a timeless fall jacket that takes full advantage of the lush self-stripping beauty of Noro Silk Garden.

Okay, so you will need to concentrate while knitting the yokes. The finishing, while decorative, will also require patience. The main body pieces and sleeves, though, are really straightforward. And the overall effect is quite striking in a twisted sort of way.

**Editor's note:** charts are in an Excel spreadsheet. Please download the [.xls](#) file and click on the tab labelled as shown in the pattern.

If you don't have Excel on your computer, you'll find a free Excel reader [PC only] [here](#).



[KNITTY FAQ](#)

[SUBMISSION  
GUIDELINES](#)

[LEGAL BITS](#)

[THE RABBIT](#)

© Knitty 2002-07  
All rights reserved.  
Reproduction  
prohibited.  
Knitty™ is a  
Trademark of  
Knitty magazine.

**model:** Sarah Fairman **photo:** Natalie Wilson

## SIZE

XS-S [M-L, XL-XXL]. Shown in Size M-L.

## FINISHED MEASUREMENTS

Chest: 41 [49, 57] inches

Length: 25 [27, 29] inches

## MATERIALS

**Noro Silk Garden** [45% silk, 45% kid mohair, 10% lambswool; 100 m per 50 g skein]; Color 47; 11 [12, 15] skeins.

*Add 1 skein if you are fussy about color placement.*

- 1** set US #8/5mm straight needles
- 1** set US #9/5.5mm straight needles
- 2** 32-inch US #9/5.5mm circular needles
- 1** Row counter
- 1** Stitch holder [4-6 inches long]
- 1** Approx. 5 yards smooth, matching yarn for sewing
- 1** Approx. 5 yards smooth, contrasting yarn for holding stitches OR four 24 to 32 inch circular needles size US#9/5.5mm or smaller
- 5** 1-inch diameter buttons
- 1** Tapestry needle

## GAUGE

17 sts/21 rows = 4" in Stockinette stitch using larger needles.

*Because pieces are worked in several different directions, it is critical to match **both** stitch and row gauge.*

## DIRECTIONS

### Right Front-Left Back

With larger straight needles, CO 56[64, 68] sts.

Row 1[RS]: K.

Row 2[WS]: K7, p to end.

Repeat Rows 1 and 2 until piece measures 20[24, 28] inches. Cut yarn, and move sts onto contrasting yarn or a spare circular needle.

### Left Front-Right Back

With larger straight needles, CO 56[64, 68] sts.



Row 1[RS]: K.

Row 2[WS]: P to last 7 sts, k7.

Repeat Rows 1 and 2 until piece measures 20[24, 28] inches.

Cut yarn, and move sts onto contrasting yarn or a spare circular needle.



### **Right Back Yoke**

Piece is worked in St st using larger needles and foll **Chart** RB1[RB2, RB3]. Count rows as you work using row counter.

For ease in working, starting edge for each row is identified by highlighting. Work each single inc or dec 1 st in from edge.

Work multiple decs by BO.

### **Left Back Yoke**

Piece is worked in St st using larger needles and foll **Chart** LB1[LB2, LB3]. Count rows as you work using row counter.

For ease in working, starting edge for each row is identified by highlighting. Work each single inc or dec 1 st in from edge.

Work multiple decs by BO.

### **Right Front Yoke**

Piece is worked in St st using larger needles and foll **Chart** RF1[RF2, RF3]. Count rows as you work using row counter.

For ease in working, starting edge for each row is identified by highlighting. Work each single inc or dec 1 st in from edge.

Work multiple decs by BO.

### **Left Front Yoke**

Piece is worked in St st using larger needles and foll **Chart** LF1[LF2, LF3]. Count rows as you work using row counter.

For ease in working, starting edge for each row is identified by highlighting. Work each single inc or dec 1 st in from edge.

Work multiple decs by BO.

### **Sleeve**

#### *Make 2*

With smaller straight needles, CO 42[42, 42] sts. K 9 rows for Garter st cuff.

Change to larger straight needles and work in St st, beg with a RS [k] row.

Inc 1 st each edge on next RS row and then every foll 5th row 8[11, 15] times and every foll 4<sup>th</sup> row 13[10, 6] times until there are 86[86, 86] sts on needle.

Work even until piece measures 21[22.5, 23.5] inches from CO edge.

Cut yarn, and move sts to contrasting yarn or spare circular needle.

### **FINISHING**

Block pieces to measurements.

### **Seams**

Slip sts from Right Front-Left Back onto larger circular needle.

Repeat for Left Front-Right Back.

Holding pieces with WSs tog, use a US#9/5.5mm straight needle to join with 3-needle bind off technique.

Using larger circular needle, pick up 46[46, 50] sts along center back edge of Left Back

see # for my joining order.

①

see # for my joining order

2

Yoke.  
Repeat for Right Back Yoke.

Holding pieces with WSs tog, and starting at upper edge, use a US#9/5.5 mm straight needle to join with 3-needle bind off technique, leaving Garter st border open at lower edge if desired. *I followed previous instructions and there is NO GARTER STITCH border on these pieces*

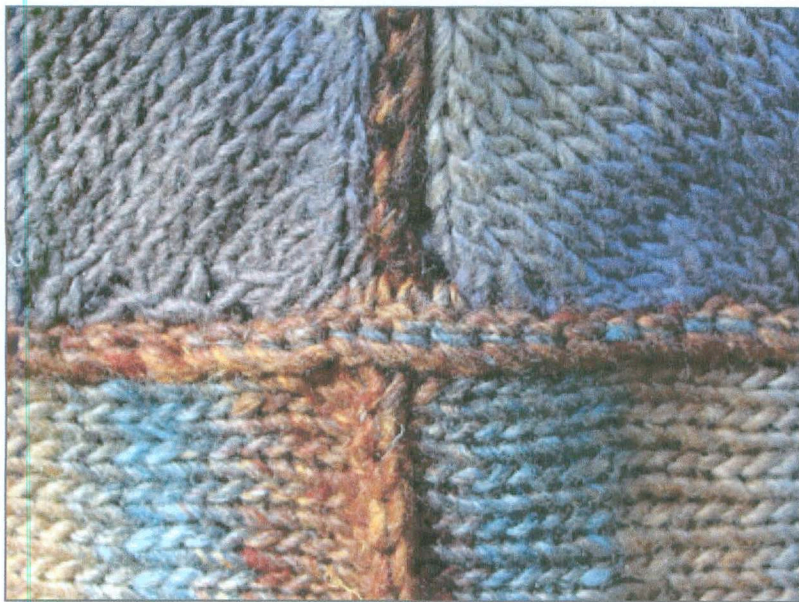

Using US #9/5.5mm circular needle, pick up 20[24, 28] sts along shoulder edge of Left Back Yoke.  
Repeat for Right Front Yoke.  
Holding pieces with WSs tog, use a US#9/5.5 mm straight needle to join with 3-needle bind off technique. Join shoulder edges of Right Back Yoke and Left Front Yoke in same manner.

3

5

Using US #9/5.5mm circular needle, pick up 160[190, 220] sts evenly along lower edge of joined yokes. With a separate US #9/5.5mm circular needle, pick up the same number of sts evenly along upper edge of the joined fronts and backs.  
Holding pieces with WS tog, use a US#9/5.5mm straight needle to join with 3-needle bind off technique, taking care to match center back seams.

*I found this impossible to do. I joined the top to the bottom after I completed the arm attachment + closing of the arm + yoke seams.*

4

Using US #9/5.5mm circular needle, pick up 86[86, 86] sts evenly along vertical edge of armhole.  
Slip sts from sleeve onto a separate US #9/5.5mm circular needle.  
Holding pieces with WSs tog, use a US#9/5.5 mm straight needle to join with 3-needle bind off technique.  
Repeat for second sleeve.  
Sew sleeves to horizontal armhole edges of yokes, and then join sleeve seams.

**Front Bands**

With smaller straight needles and RS facing, pick up 85[92, 100] sts evenly along left front edge.  
Work in Garter st for 1.25 inches. BO knitwise.  
Mark positions for five buttons: The first 0.75 inches from neck edge, the last 1.5 inches from lower edge, and the rem 3 spaced evenly between.  
With smaller straight needles and RS facing, pick up 85[92, 100] sts evenly along right front edge. Work in Garter st for 0.5 inches, ending with a WS row.

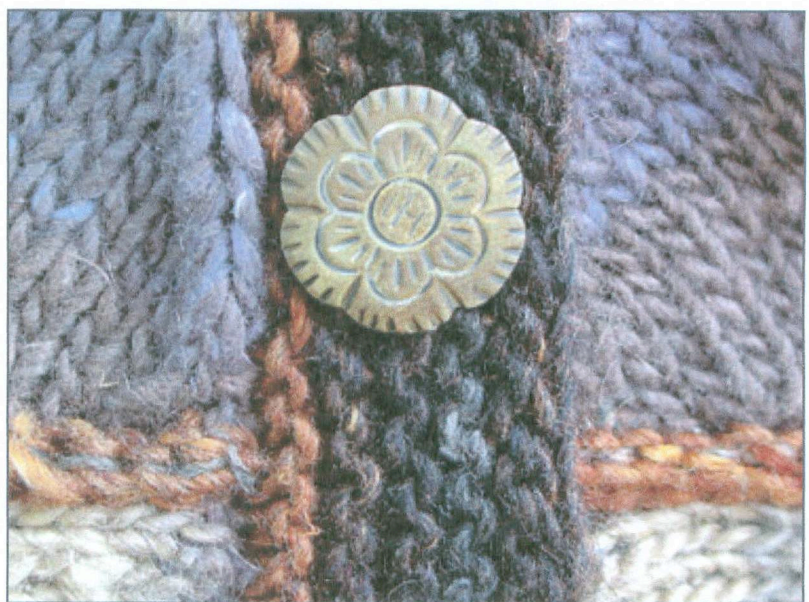

*the top + bottom + every-thing hangs nicely.*

*I did a  
2- bind off  
buttonhole &  
recast on the  
2 stitches on  
the following  
row.*

Next row [buttonhole row]: \*k to buttonhole position, yo, k2tog; rep from \* until five buttonholes have been formed, then k to end.  
Continue in Garter st until band measures 1.5 inches.  
BO knitwise.

### Collar

With smaller straight needles and RS facing, pick up 85[95, 105] sts evenly along neck edge.

Work in Garter st for 1.5 inches.

Change to larger needles.

Work in Garter st until collar measures 4 inches.

BO knitwise.

Weave in all yarn ends. Sew buttons in marked positions opp buttonholes.  
Steam block.

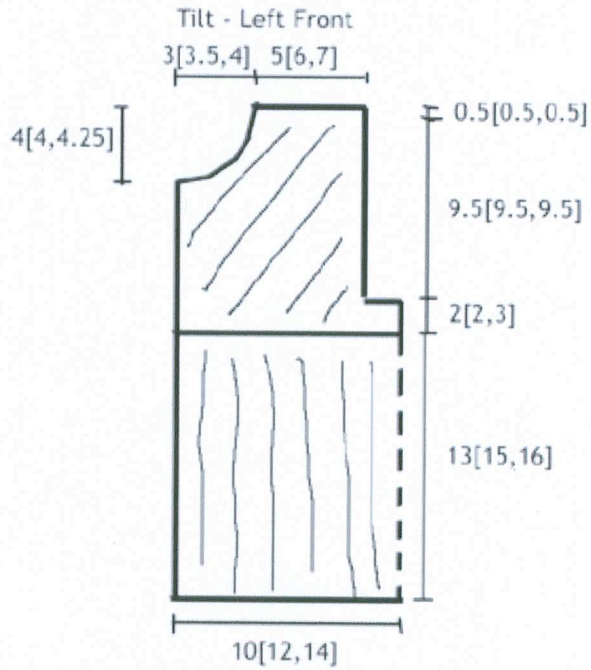

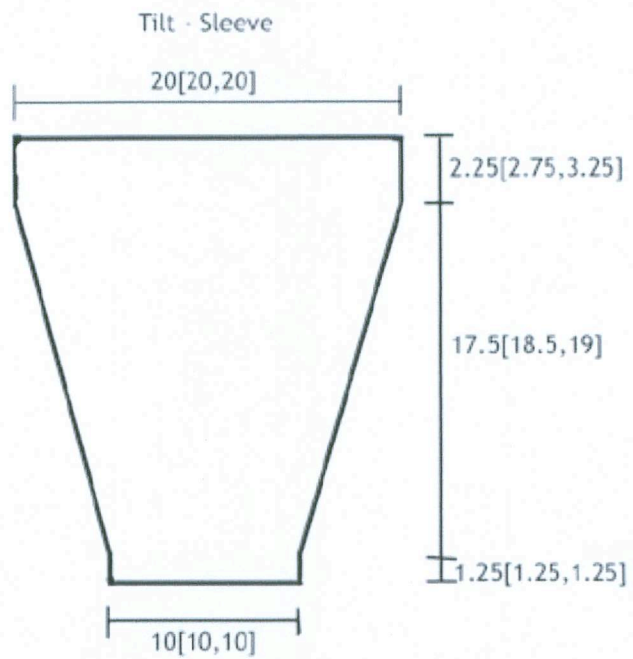
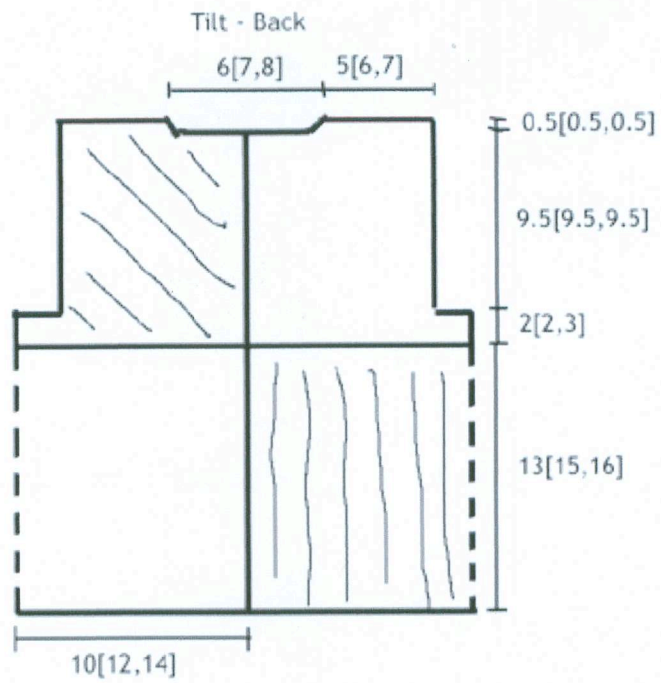

#### ABOUT THE DESIGNER



Natalie is a wife, mother, knitting teacher, knitwear designer, and yarn accumulator in the Detroit area -- and she's doing it all at full tilt!